

**O-CS41-XXXXYZ-X-X-XX-X - FREQ**  
**Precision Ultra Low Phase Noise OCXO in 41x30 mm**  
**SMD Package with OSC Disable and Oven Alarm**  
**features for Instrumentation**

**Product Data Sheet**

**Features**

- SC-cut crystal
- High Stability
- Low Aging
- Ultra Low Phase Noise
  - Ultimate (U) -146 dBc/Hz at 10Hz
  - 172 dBc/Hz on the floor
  - Extraordinary(E) -120 dBc/Hz at 1 Hz
  - 148 dBc/Hz at 10 Hz
  - 172 dBc/Hz on the floor

**Applications**

- Instrumentation
- Radar
- Satellite Communications
- Reference
- COTS/Dual use

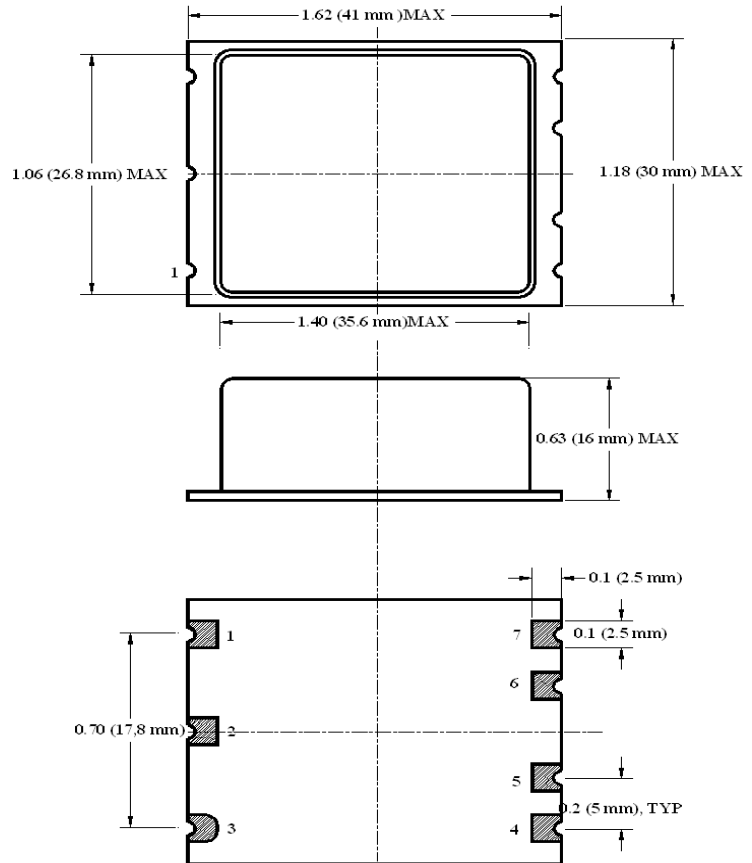



Rev. C

<b>Control voltage</b>	Vc	No internal bias	0 -4.0 0		Vref 4.0 10	V	Slope option "P" Slope option "N" Slope option "L"
<b>Reference Voltage</b>	Vref	Vcc = 12V Vcc = 5V		5 or 4.5 4.5		V	N/A w/slope options "N" and "L"
<b>Output Impedance</b>		At Vref pin		100		Ohm	
<b>Pull range</b>		from nominal F	±0.4	±0.6		ppm	
<b>Deviation slope</b>		Monotonic, positive Monotonic, negative Monotonic, positive		1.0/Vref -0.13 0.12		ppm/V	Slope option "P" Slope option "N" Slope option "L"
<b>Setability</b>	Vc0	@25°C, Fnom.  No internal bias for slope option "L"		Vref/2 ± 0.5 0 ± 0.5 5 ± 0.5		V	Slope option "P" 3* Slope option "N" Slope option "L"
<b>Oven Ready</b>		V pin #7	3.3		0.5	V	Ready Not Ready
<b>Output Enable</b>		CMOS Logic "1" (4.5V > V > 2.5) or floating Logic "0" (V < 0.5V)		Enabled  Disabled		V	  Pout < -30 dBm
<b>Modulation Bandwidth</b>	Fm		DC		1	KHz	Note 5

**Notes:**

- \*. For highest operating temperature higher than 70°C the power consumption will be higher (about 20% for 85°C). Values listed are for test in still air environment, the values will go up while testing in the temperature chamber.
- 2\*. It is recommended to specify Slope option "N" for Ultimate Phase noise performance. For recommended phase noise test, contact factory. It's assumed that phase noise test is performed under static conditions (no vibration), in still air, and care is taken for minimizing EMI.
- 3\*. Longer storage time, especially at low temperatures, may affect both retrace and setability parameters. It may require few days on power for re-stabilization.
- 4. All parameters, unless otherwise specified, are at nominal conditions, ie: T=25°C, Nominal Vcc & Nominal Load.

**Environmental and Mechanical**

<b>Operating temp. range</b>	0°C to 70°C TYP. See table below to specify
<b>Mechanical Shock</b>	Per MIL-STD-202, 30G, 11ms
<b>Vibration</b>	Per MIL-STD-202, 5G to 2000 Hz
<b>Soldering Conditions</b>	See profile below. The device may be reflowed once. Reflowing upside down is not allowed. Hand soldering is highly encouraged. NO CLEAN assembly is recommended

**Electrical Connections**

<b>Pin Out</b>	Pad #1- GND; Pad#2 – Oven Ready indicator; Pad #3 – RF Output; Pad #4 – Vcc; Pad #5 – Output Enable; Pad #6 – Vc; Pad #7 – Vref
----------------	---



## MAX Reflow Profile

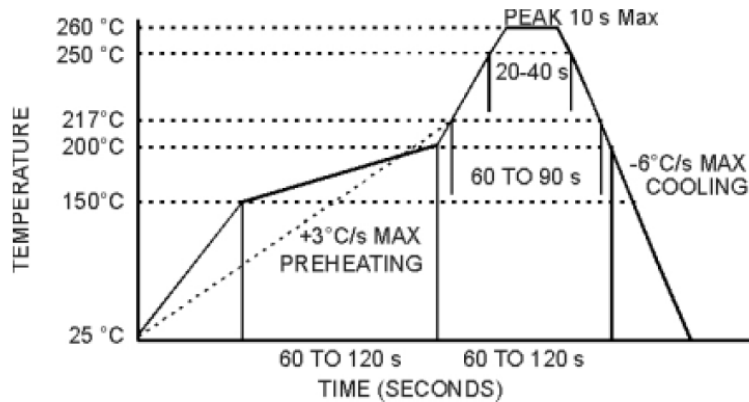

## Creating a Part Number

**Q** - **C** **S41** **X** **X** **YZ** **XX** - **X** - **X** - **XX** - **X** - FREQ  
**OCXO** | **Conventional Power** | **Package Code** | **Supply Voltage** | **Output** | **Temperature Stability** | **Temperature Range** | **Environmental** | **Aging** | **Phase Noise (See Table)** | **Deviation slope**

**Package Code**  
SMD 41x30x16, 7 pads

### Supply Voltage

Code	Specification
0	5V ± 5%
F	12V ± 5%

### Output

Code	Specification
T	CMOS/TTL
S	Sinewave

### Temperature Stability

Code	Specification
17	1x10 <sup>-7</sup>
58	5x10 <sup>-8</sup>
28	2x10 <sup>-8</sup>
18	1x10 <sup>-8</sup>
59	5x10 <sup>-9</sup>
YZ	Yx10 <sup>-Z</sup>

### Temperature Range

Code	In 5°C steps **
First letter	Lowest temperature from A = -40°C
Second letter	Highest temperature to Z = 85°C
Examples	
AZ	-40°C to 85°C
GU	-10°C to 60°C
EW	-20°C to 70°C

### Environmental

Code	Specification
L	Contains a level of lead that is in excess of RoHS directive and is not designed for reflow
R	RoHS compliant, not designed for reflow

### Aging

Insert Value per day times 1E-10	
Examples	
05	5E-10 = 0.5 ppb/day
10	1E-9 = 1 ppb/day

### Phase Noise (See Table)

Code	Specification
L	Standard
P	Premium
U	Ultimate
E	Extraordinary

### Deviation slope

Code	Specification
P	Positive, 0 to Vref
N	Negative, -4 to 4V
L	Positive, 0 to 10 V



**\*\*Temperature Code Table**

Letter	Temp °C	Letter	Temp °C	Letter	Temp °C	Letter	Temp °C	Letter	Temp °C	Letter	Temp °C
A	-40	F	-15	K	10	P	35	U	60	Z	85
B	-35	G	-10	L	15	Q	40	V	65		
C	-30	H	-5	M	20	R	45	W	70		
D	-25	I	0	N	25	S	50	X	75		
E	-20	J	5	O	30	T	55	Y	80		

